

# Industrial air cooler VCI

## Cooling/Freezing

Cu/Al - R404A

GEA Refrigeration



Goedhart



# Goedhart VCI

The extensive range Goedhart VCI single discharge ceiling mounted industrial air coolers are available with capacities between 3,4 and 149 kW. The Goedhart VCI air coolers are suitable for cooling and freezing applications and with a wide variety of accessories and options available. The coil block is standard build from aluminium end plates, copper tubes and aluminium fins. The fans are arranged for blow-through air configuration for the Goedhart VCI-B and draw-through for the Goedhart VCI-Z (please state which is required when ordering).. The modular design incorporates 5 different sizes of fan, with model options of up to 8 fans per cooler.

## Type description

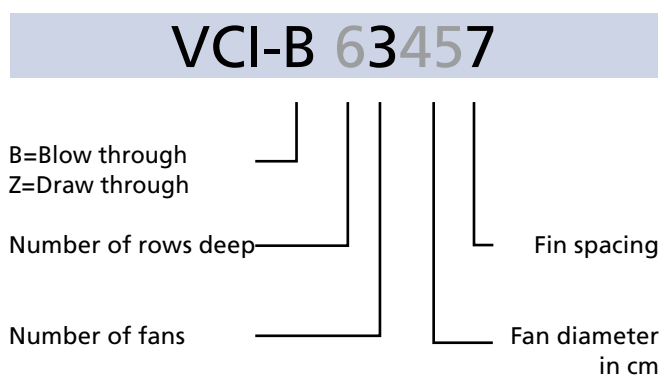

## Coil block

- Tube pitch : 50x50 mm straight
- Fin spacing : 4, 6, 7, 8 and 10 mm
- Material : 15mm o.d copper tube
- : aluminium HT-lamellen
- Optimized cooling circuits
- Standard refrigerant connections are positioned on the left hand side of the unit when looking with the direction of the airflow.
- A good thermal contact is achieved by expansion of the tubes into the fin collars, that are also utilised as spacers to provide a constant distance between the fins.
- All coolers are pressure tested to 30 bar (lower by cooling mediums) and are supplied with a light over pressure charge of dry nitrogen.
- Suitable for all known refrigerants and coolants, with the exception of NH3.

## Casing

- Construction for ceiling mounting
- The flush mounting protects against and prevents accumulation of dust and dirt.
- Casing material of galvanized sheet steel
- Finishing is standard white epoxy spray (RAL 9003)
- Bend/header projection by end covers, easy removed for maintenance
- Hinged drip tray.
- Defrost by hot gas spiral or electric defrost elements will be fixed to the bottom side of the coil.

# General range features

## Capacity

The listed nominal cooling capacities are based on R404A en DT1

### Influence of Coating on Capacity

The use of coated fins, or of a fully coated coil will result in a capacity decrease of approximately 3%

### Capacity optimisation

Since Goedhart tries to limit stock products, we are capable of optimising the circuitry of our evaporators. In order to do this, the following information is needed :

- Design capacity
- Air volume
- Refrigerant
- Air on temperature
- Evaporating temperature
- Liquid temperature before expansion valve.

## Sound data

The mean sound pressure (LpA @ 3m ± 2 dB (A)) each air cooler is a calculated indication value according to the EN13487 standard parallel pipe. Goedhart uses the fan manufacturer's sound power level (LwA) at the inlet side of the fan. Changes to or by the fan or the product, affect the sound, in these cases, consult the manufacturer for the new indication value. In critical sound requirements, we advise you to consult an expert.

## Defrostsystem:

For room temperatures where ice build-up can be expected and where the coilblock can not be defrosted by the room air, electric or hotgas defrost is necessary.

With low temperatures we also advise fan periphery heating.

### Electrical defrost:

The Goedhart VRB and VRZ can be provided with electric defrost. A distinction can be made here between heavy defrost loads for low temperatures and light defrost load for higher temperatures (room temperature approximately 0 °C). The stainless steel heater elements are fitted in the coilblock in tubes, which forms a high conductive medium between the heaters and the fins. The driptray heaters are fitted to the underside of the aluminium inner tray with aluminium profiles. The heater elements which are rated for 220/240 V are connected for supply 380/415 V with neutral. The coilblock elements are removable from the end opposite to the refrigerant connections, whilst the tray heater elements can

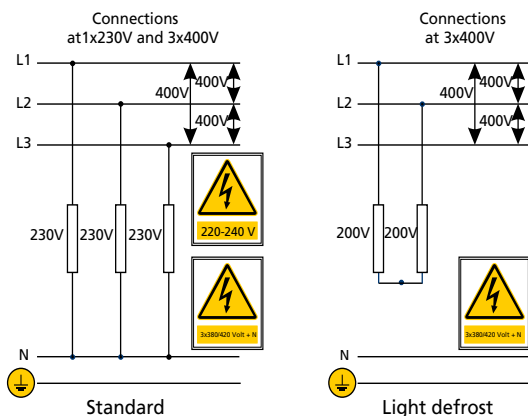

be removed once the outer tray has been taken off.

### Hot gas defrost:

The coil block is suited for hot gas defrost (hot gas supply through the suction header). At an extra price the driptray can be provided with a hotgas/cooling medium spiral. The stainless steel tubes of the hotgas spiral are enclosed in special aluminium profiles that are rigidly secured to the underside of the aluminium inner tray, thus providing a good bond for maximum heat transfer. Just as with electric defrost a distinction is made with hotgas defrost between light defrost load (room temperature about 0°C) and heavy defrost load.

### Accessories:

Standard accessories for the Goedhart VCI air coolers are:

- blow-through / draw-through air configuration
- Electric defrost, hot gas defrost and/or water defrost
- Fan periphery heating
- Insulated drip tray
- Insulated hygienic polyester drip tray
- Goedhart VCI-Z supplied with bellmouth connection per fan for a longer air throw
- Goedhart VCI-B supplied with air diffusor for a longer air throw
- Goedhart VCI-B supplied with air diffusor with air operated damper to increase defrost efficiency (airvolume reduced to approx. 90% and capacity reduced to approx. 95%)

The accessories are included in the price list.

### Optional extras:

Various optional extras for the VCI are available, price and delivery upon request:

- Isulation disks
- Feet for floor mounting
- Coating of the coil block
- Fan hood
- 60 Hz motors
- EC-fans
- Single phase motors
- Coolants (glycol, water, etc.)
- Pump system
- Other casing materials
- Other fin spacings
- Sea water resistant fins

## Mounting and Maintenance

Goedhart VCI is delivered on a wooden frame. When on the frame, Goedhart VCI can be handled by forklift truck, which makes positioning and installation simple. Refer to our maintenance and installation manual.



# Fans

The manufacturer of the fans is Süd Electric (we reserve the right to alter the manufacturer). The fans have glass fibre reinforced polypropylene impellers. The motors are available for 400V-50Hz-3 phase or 230V-50Hz-1 phase electrical supply. 2-Speed regulation can be achieved at 400/690V-50Hz-3 phase by using a Δ-Y reconnection (fig. 1). 3 Phase motors are suitable for a frequency controller (A sinus filter is needed, fig. 2). 1 Phase motors are suitable for phase control and transformer. The motors are standard executed with a thermo contact. The fans are suitable for operation in air temperature applications between -40 °C and +45 °C. When the air temperature is lower than -40 °C, special fans are needed. These special fans have a longer delivery time. The technical data in the table below are the same as on the motor name plates and is valid for an air temperature of +40 °C.

For air temperatures lower than +40 °C, the current amperage can be calculated by using the diagram multiplication factor, suitable thermal overloads can then be selected.

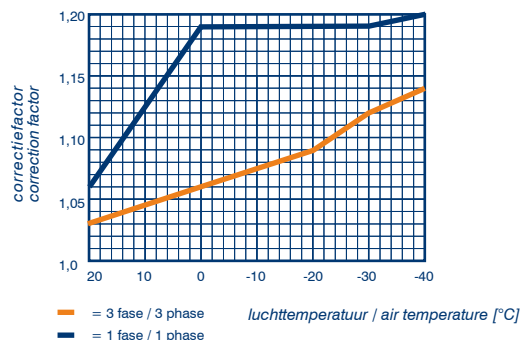

## Three phase - 50 Hz

Fan type	Tension	Δ				Y			Protection class*	Fan heating
		Speed	Input	FLC	Sound power indication each fan LwA (+/-2dB(A))	Speed	Input	FLC		
		min <sup>-1</sup>	Watt	A	dB(A)	min <sup>-1</sup>	Watt	A		

### 4 pole motor (n=1500 rpm nom.)

400-32°	3x400/690	1350	250	0.60	74	1050	150	0.30	IP44	460
450-32°	3x400/690	1350	400	0.85	78	1050	300	0.50	IP44	580
500-40°	3x400/690	1380	880	1.90	85	1050	660	1.15	IP44	580
560-36°	3x400/690	1300	1250	2.30	85	1000	750	1.30	IP66	700
630-32°***	3x400/690	1300	1250	2.30	86	1000	750	1.30	IP66	820
630-28°***	3x230/400				88	1400	1400	2.50	IP66	820

### 6 pole motor (n=1000 rpm nom.)

400-28°	3x400/690	900	105	0.33	63	750	65	0.13	IP44	460
450-32°	3x400/690	900	180	0.40	69	750	120	0.20	IP44	580
500-40°	3x400/690	900	500	1.00	81	760	350	0.65	IP44	580
560-32°	3x400/690	880	680	1.60	75	680	400	0.90	IP66	700
630-36°	3x400/690	880	680	1.60	80	680	400	0.90	IP66	820

## Single phase - 50 Hz

Ventilator type	Speed	Input	FLC	Protection class*
	min <sup>-1</sup>	Watt	A	

### 4 pole motor (n=1500 rpm nom.)

400-32°	1350	450	1.95	IP44
450-32°	1350	450	1.95	IP44
500-40°	1330	700	3.40	IP44
560-36°	1350	920	4.00	IP66
630-32°	1350	1300	7.10	IP66

### 6 pole motor (n=1000 rpm nom.)

400-28°	900	250	1.10	IP44
450-32°	900	250	1.10	IP44
500-40°	900	400	1.75	IP44
560-32°	870	700	3.40	IP66
630-36°	870	700	3.40	IP66

\*= IP44 motors also available in IP66 execution (extra price)

\*\*= Only cooling conditions

\*\*\*= Only freezing conditions

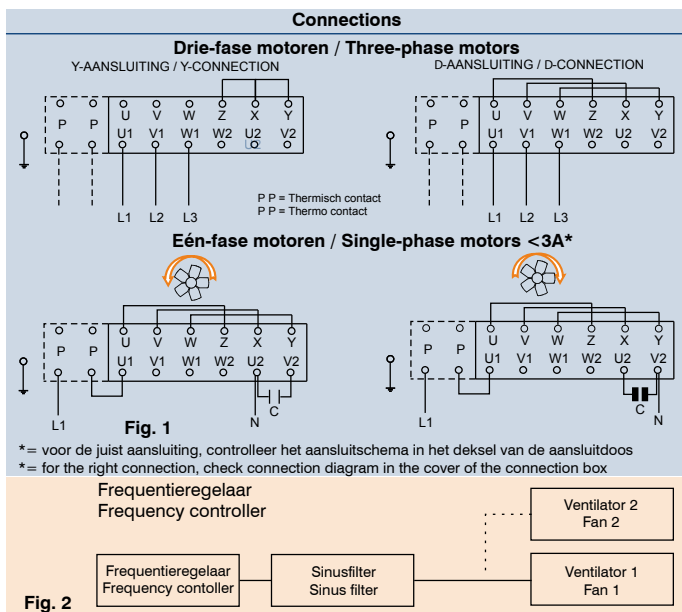

# Correction factors

## Correction factors DT1 (=air-on)

The capacities are based on R-404A direct expansion, DT1 and a RH of 85 %. DT1 is the difference between air-on temperature and the evaporation temperature of the cooler. The evaporation temperature is the saturate temperature corresponding to the pressure at the suction outlet of the cooler.

The nominal capacities: (SC1)  $t_o=0^{\circ}\text{C}$  and  $\text{DT1}=10\text{K}$   
 (SC2)  $t_o=-8^{\circ}\text{C}$  and  $\text{DT1}=8\text{K}$   
 (SC3)  $t_o=-25^{\circ}\text{C}$  and  $\text{DT1}=7\text{K}$

Correction factors for various air-on temperatures and temperature differences (DT1) are as indicated in the table below. The requested capacity must be multiplied by a correction factor from the table. so that a cooler with the resulting nominal capacity can be chosen from the selection tables.

$Q_{\text{nominal}} = \text{factor} \times Q_{\text{requested}}$

## Cooling

DT1	SC1-DT1 =10K-Air-on=10°C (0/+10)									
	Evaporation temperature (°C)									
K	+7	+6	+5	+4	+3	+2	+1	0	-1	-2
6	1,87	1,87	1,87	1,88	1,88	1,89	1,89	1,89	1,89	1,90
7	1,53	1,53	1,54	1,54	1,54	1,55	1,55	1,55	1,55	1,56
8	1,28	1,28	1,28	1,29	1,29	1,30	1,30	1,30	1,30	1,31
9	1,11	1,11	1,11	1,12	1,12	1,13	1,13	1,13	1,13	1,14
10	0,98	0,98	0,98	0,99	0,99	0,99	1,00	1,00	1,00	1,01
11	0,89	0,89	0,89	0,90	0,90	0,91	0,91	0,91	0,91	0,92
12	0,78	0,79	0,79	0,79	0,80	0,80	0,80	0,80	0,80	0,81

## Cooling / Freezing

DT1	SC2-DT1 =8K-Air-on=0°C (-8/0)									
	Evaporation temperature (°C)									
K	-3	-4	-5	-6	-7	-8	-9	-10	-11	-12
6	1,32	1,34	1,39	1,43	1,46	1,46	1,47	1,47	1,48	1,49
7	1,05	1,08	1,12	1,15	1,18	1,19	1,19	1,20	1,20	1,21
8	0,86	0,88	0,91	0,94	0,97	1,00	1,00	1,01	1,01	1,02
9	0,76	0,76	0,78	0,80	0,82	0,86	0,86	0,87	0,87	0,88
10	0,66	0,67	0,69	0,71	0,73	0,74	0,74	0,75	0,75	0,76
11	0,58	0,59	0,59	0,60	0,62	0,64	0,64	0,65	0,66	0,67
12	0,55	0,54	0,54	0,54	0,55	0,55	0,56	0,57	0,58	0,59

## Freezing

DT1	SC3-DT1 =7K-Air-on=-18°C (-25/-18)									
	Evaporation temperature (°C)									
K	-21	-22	-23	-24	-25	-26	-27	-28	-29	-30
6	1,20	1,20	1,21	1,21	1,22	1,22	1,23	1,23	1,24	1,24
7	0,99	0,99	0,99	1,00	1,00	1,00	1,01	1,01	1,02	1,02
8	0,83	0,84	0,84	0,84	0,85	0,85	0,85	0,85	0,86	0,86
9	0,72	0,72	0,72	0,73	0,73	0,73	0,73	0,74	0,74	0,74
10	0,63	0,63	0,63	0,64	0,64	0,64	0,64	0,65	0,65	0,65
11	0,56	0,56	0,56	0,57	0,57	0,57	0,50	0,58	0,58	0,58
12	0,50	0,51	0,51	0,51	0,51	0,51	0,52	0,52	0,52	0,52

## Rekenvoorbeeld

Lamelafstand	: 6 mm	-	DT1 = +3- (+10) = 7K
Gevraagde capaciteit	: 30 kW	-	Correctiefactor = 1,54
Luchtintrede temperatuur	: +10 oC	-	Vermenigvuldig gevraagde capaciteit met correctie factor.
Verdampingstemperatuur	: +3 oC		30 kW x 1,54 = 46,2 kW
Euroventconditie	: SC1		
Koudemiddel	: R-404A	-	Selecteer luchtkoeler uit tabel (SC1 type VCI-B 44566=46,5 kW)

# Attention!

### Moisture carry over from the coil block:

When you select VCI-B with a Ø500 mm fan in an application with a high relative humidity and/or defrost with room air, Goedhart advises the use of a fan with a low pitch angle or the draw-through execution VCI-Z. Thus, you will avoid the risk of moisture carry over from the coil block. The fan with a low pitch angle give a reducing of the capacity of approx. 5% and a reduction of the air volume of approx. 10%.

### Air throw\*\* (only draw-through execution)

The air throw mentioned in the selection table indicated with \*\* is based on an air temperature of 20°C, blowing under a flat ceiling without any obstruction. The height and air circulation fold of the room can influence the air throw. The air speed at the end of the throw-length is 0,25 m/sec

# VCI 4mm Technical data

Type VCI	3x400V-50H-4pole (1500 min <sup>-1</sup> nom.)						Dimensions										Connections				
	R404A			Air volume m <sup>3</sup> /h	LpA @ 3 m (± 2 dB(A))*	Surface m <sup>2</sup>	Internal volume dm <sup>3</sup>	Weight kg	L mm	B mm	H mm	D mm	E1 mm	E2 mm	E3 mm	D1 mm	D2 mm	Refrigerant			
	DT1 = 10K (SCT) lucht on= 0°C (0/+10)	DT1 = 8K (SCT) lucht on= 0°C (-8/0)	DT1 = 7K (SCT) lucht on= -18°C (-25/-18)															In mm	Uit mm	Hot gas mm	Air throw** m
4.1.40.4	7,1			3079	52	38	6	72	1156	670	620	500		756		578		15	15	19	20
6.1.40.4	9,7			2820	52	57	9	90	1156	770	620	600		756		578		12	22	19	20
4.1.45.4	11,6			4652	56	52	8	88	1256	670	720	500		856		628		12	22	19	22,5
6.1.45.4	14,0			4269	56	78	12	110	1256	770	720	600		856		628		12	22	19	22,5
4.1.50.4	15,3			6648	63	65	10	110	1456	790	720	600		1056		728		12	22	19	25
6.1.50.4	19,0			6124	63	97	15	137	1456	890	720	700		1056		728		12	28	19	25
4.1.56.4	23,1			9704	63	95	14	153	1556	910	920	700		1156		778		12	28	19	27,5
6.1.56.4	27,8			9077	63	142	21	189	1556	1010	920	800		1156		778		16	28	35	27,5
4.1.63.4	30,5			12209	63	129	19	193	1656	910	1120	700		1256		828		16	35	35	27,5
6.1.63.4	36,7			11498	63	194	29	239	1656	1010	1120	800		1256		828		16	35	35	27,5
4.2.40.4	15,1			6149	55	75	11	119	1856	670	620	500		1456		928		12	22	19	20
6.2.40.4	19,5			5629	55	113	17	149	1856	770	620	600		1456		928		12	28	19	20
4.2.45.4	24,0			9291	59	103	15	147	2056	670	720	500		1656		1028		16	28	19	22,5
6.2.45.4	28,2			8522	59	155	23	186	2056	770	720	600		1656		1028		16	35	35	22,5
4.2.50.4	31,2			13283	66	129	19	187	2456	790	720	600		2056		1228		16	35	35	25
6.2.50.4	38,9			12233	66	194	29	237	2456	890	720	700		2056		1228		16	35	35	25
4.2.56.4	47,1			19392	66	190	28	262	2656	910	920	700		2256		1328		16	42	35	27,5
6.2.56.4	56,2			18134	66	285	42	330	2656	1010	920	800		2256		1328		16	42	35	27,5
4.2.63.4	62,3			24402	66	259	38	335	2856	910	1120	700		2456		1428		22	42	35	27,5
6.2.63.4	75,4			22978	66	388	57	422	2856	1010	1120	800		2456		1428		22	54	35	27,5
4.3.45.4	36,3			13929	61	155	23	207	2856	670	720	500		2456		1428		16	35	35	22,5
6.3.45.4	43,4			12776	61	233	34	263	2856	770	720	600		2456		1428		16	42	35	22,5
4.3.50.4	48,8			19918	67	194	29	265	3456	790	720	600	1028		2028	864	1728	16	42	35	25
6.3.50.4	58,9			18341	67	291	43	338	3456	890	720	700	1028		2028	864	1728	16	42	35	25
4.3.56.4	67,0			29081	67	284	42	372	3756	910	920	700	1128		2228	939	1878	16	42	35	27,5
6.3.56.4	87,6			27192	67	427	62	470	3756	1010	920	800	1128		2228	939	1878	22	54	42	27,5
4.3.63.4	93,0			36595	67	388	57	478	4056	910	1120	700	1228		2428	1014	2028	22	54	35	27,5
6.3.63.4	114,9			34458	67	582	85	605	4056	1010	1120	800	1228		2428	1014	2028	22	54	42	27,5
4.4.45.4	48,6			18568	62	207	30	264	3656	670	720	500	1628		1628	914	1828	16	42	35	22,5
6.4.45.4	57,4			17030	62	310	45	339	3656	770	720	600	1628		1628	914	1828	16	42	35	22,5
4.4.50.4	63,8			26553	68	258	38	342	4456	790	720	600	2028		2028	1114	2228	16	42	35	25
6.4.50.4	79,0			24449	68	388	57	438	4456	890	720	700	2028		2028	1114	2228	22	54	35	25
4.4.56.4	95,2			38770	68	379	55	481	4856	910	920	700	2228		2228	1214	2428	22	54	42	27,5
6.4.56.4	114,0			36251	68	569	83	609	4856	1010	920	800	2228		2228	1214	2428	22	54	42	27,5
4.4.63.4	125,9			48790	68	517	75	620	5256	910	1120	700	2428		2428	1314	2628	22	54	42	27,5
6.4.63.4	152,8			45937	68	776	113	789	5256	1010	1120	800	2428		2428	1314	2628	28	64	42	27,5
4.5.45.4	59,9			23206	62	258	38	324	4456	670	720	500	1628		2428	1114	2228	16	42	35	22,5
6.5.45.4	72,8			21284	62	388	57	417	4456	770	720	600	1628		2428	1114	2228	22	42	35	22,5
4.5.50.4	82,7			33189	69	323	47	419	5456	790	720	600	2028		3028	1364	2728	22	54	35	25
6.5.50.4	99,4			30557	69	485	71	537	5456	890	720	700	2028		3028	1364	2728	22	54	42	25
4.6.45.4	73,3			27846	63	310	45	385	5256	670	720	500	2428		2428	1314	2628	22	42	35	22,5
6.6.45.4	85,7			25537	63	465	68	494	5256	770	720	600	2428		2428	1314	2628	22	54	42	22,5
4.6.50.4	98,4			39823	69	388	57	496	6456	790	720	600	2028	2000	2028	1076	2x2152	22	54	42	25
6.6.50.4	119,3			36665	69	582	85	637	6456	890	720	700	2028	2000	2028	1076	2x2152	22	54	42	25
4.7.45.4	85,6			32484	63	362	53	443	6056	670	720	500	2428	800	2428	1514	3028	22	54	42	22,5
6.7.45.4	102,6			29791	63	543	79	569	6056	770	720	600	2428	800	2428	1514	3028	22	54	42	22,5
4.8.45.4	98,0			37123	64	414	60	502	6856	670	720	500	2428	1600	2428	1143	2x2285	22	54	42	22,5
6.8.45.4	116,0			34045	64	621	90	646	6856	770	720	600	2428	1600	2428	1143	2x2285	22	54	42	22,5

\* = Sound pressure indication (LpA) at 3 m distance each air cooler (± 2 dB(A)), free field conditions, according EN13487

\*\* = Air throw see remark page 5

For moisture carry over see remark page 5









# VCI 10mm Technical data

Type VCI	3x400V-50H-4pole (1500 min <sup>-1</sup> nom.)								Dimensions								Connections				
	R404A			Air volume	LpA @ 3 m (+/- 2 dB(A))*	Surface	Internal volume	Weight	L	B	H	D	E1	E2	E3	D1	D2	Refrigerant			
	DT1 = 10K (SC1) lucht on= 0°C (0/+10)	DT1 = 8K (SC2) lucht on= 0°C (-8/0)	DT1 = 7K (SC3) lucht on= -18°C (-25/-18)															In	Uit	Hot gas	Air throw**
	kW	kW	kW	m <sup>3</sup> /h	dB(A)	m <sup>2</sup>	dm <sup>3</sup>	kg	mm	mm	mm	mm	mm	mm	mm	mm	mm	mm	mm	mm	mm
8.1.40.10		5,4	3,9	3374	52	32	11	89	1156	870	620	700		756		578		12	22	19	20
1.1.40.10		6,2	4,4	3289	52	40	14	103	1156	970	620	800		756		578		12	22	19	20
8.1.45.10		7,8	5,7	5112	56	44	16	107	1256	870	720	700		856		628		12	22	19	22,5
1.1.45.10		9,1	6,5	4973	56	55	19	122	1256	970	720	800		856		628		12	22	19	22,5
8.1.50.10		10,6	7,6	7264	63	54	19	131	1456	990	720	800		1056		728		12	22	19	25
1.1.50.10		12,3	8,8	7081	63	68	24	150	1456	1090	720	900		1056		728		12	28	19	25
8.1.56.10		15,0	10,3	10413	63	80	28	179	1556	1110	920	900		1156		778		12	28	19	27,5
1.1.56.10		17,5	12,2	10203	63	100	35	203	1556	1210	920	1000		1156		778		12	28	19	27,5
8.1.63.10		19,1	14,1	12957	63	109	38	222	1656	1110	1120	900		1256		828		16	35	19	27,5
1.1.63.10		23,1	16,5	12743	63	137	47	253	1656	1210	1120	1000		1256		828		16	35	19	27,5
8.2.40.10		10,8	7,8	6742	55	64	22	143	1856	870	620	700		1456		928		12	22	19	20
1.2.40.10		12,4	8,9	6570	55	80	28	163	1856	970	620	800		1456		928		12	28	19	20
8.2.45.10		15,5	11,3	10217	59	87	30	174	2056	870	720	700		1656		1028		16	28	19	22,5
1.2.45.10		18,2	12,9	9937	59	109	38	200	2056	970	720	800		1656		1028		16	28	19	22,5
8.2.50.10		21,1	15,2	14520	66	109	38	220	2456	990	720	800		2056		1228		16	35	19	25
1.2.50.10		24,6	17,6	14151	66	137	47	251	2456	1090	720	900		2056		1228		16	35	19	25
8.2.56.10		30,2	20,7	20817	66	160	55	301	2656	1110	920	900		2256		1328		16	42	35	27,5
1.2.56.10		35,1	24,4	20395	66	200	69	345	2656	1210	920	1000		2256		1328		16	42	35	27,5
8.2.63.10		38,4	28,1	25907	66	219	75	382	2856	1110	1120	900		2456		1428		16	42	35	27,5
1.2.63.10		43,5	32,2	25475	66	273	94	439	2856	1210	1120	1000		2456		1428		22	42	35	27,5
8.3.45.10		23,7	17,0	15321	61	131	45	244	2856	870	720	700		2456		1428		16	35	19	22,5
1.3.45.10		27,1	19,6	14901	60	164	57	282	2856	970	720	800		2456		1428		16	35	35	22,5
8.3.50.10		31,3	22,8	21776	67	164	57	310	3456	990	720	800	1028		2028	864	1728	16	42	35	25
1.3.50.10		37,0	26,3	21221	67	205	71	356	3456	1090	720	900	1028		2028	864	1728	16	42	35	25
8.3.56.10		45,9	33,3	31221	67	240	83	426	3756	1110	920	900	1128		2228	939	1878	22	42	35	27,5
1.3.56.10		53,6	38,4	30589	67	301	103	488	3756	1210	920	1000	1128		2228	939	1878	22	54	35	27,5
8.3.63.10		59,8	42,8	38854	67	328	113	541	4056	1110	1120	900	1228		2428	1014	2028	22	54	35	27,5
1.3.63.10		68,9	49,7	38208	67	410	141	623	4056	1210	1120	1000	1228		2428	1014	2028	22	54	35	27,5
8.4.45.10		30,9	22,6	20425	61	175	60	312	3656	870	720	700	1628		1628	914	1828	16	42	35	22,5
1.4.45.10		36,3	25,8	19864	61	218	75	360	3656	970	720	800	1628		1628	914	1828	16	42	35	22,5
8.4.50.10		42,9	30,3	29031	68	218	75	398	4456	990	720	800	2028		2028		2228	16	42	35	25
1.4.50.10		49,5	34,7	28291	68	273	94	457	4456	1090	720	900	2028		2028	1114	2228	22	54	35	25
8.4.56.10		61,3	41,3	41626	68	321	110	547	4856	1110	920	900	2228		2228	1214	2428	22	54	35	27,5
1.4.56.10		71,2	48,7	40780	68	401	137	629	4856	1210	920	1000	2228		2228	1214	2428	22	54	35	27,5
8.4.63.10		78,0	56,2	51803	68	437	150	702	5256	1110	1120	900	2428		2428	1314	2628	22	54	42	27,5
1.4.63.10		90,8	64,4	50941	68	547	187	807	5256	1210	1120	1000	2428		2428	1314	2628	22	54	42	27,5
8.5.45.10		39,7	27,8	25530	62	218	75	381	4456	870	720	700	1628		2428	1114	2228	16	42	35	22,5
1.5.45.10		45,5	32,2	24827	62	273	94	441	4456	970	720	800	1628		2428	1114	2228	22	42	35	22,5
8.5.50.10		53,9	37,7	36287	69	273	94	487	5456	990	720	800	2028	1000	2028	1364	2728	22	54	35	25
1.5.50.10		61,9	43,9	35361	69	341	117	562	5456	1090	720	900	2028	1000	2028	1364	2728	22	54	35	25
8.6.45.10		47,5	34,0	30633	63	262	90	451	5256	870	720	700	2428		2428	1314	2628	22	42	35	22,5
1.6.45.10		54,2	39,1	29791	63	328	113	522	5256	970	720	800	2428		2428	1314	2628	22	54	35	22,5
8.6.50.10		63,4	45,5	43543	69	328	113	576	6456	990	720	800	2028	2000	2028	1076	2x2152	22	54	35	25
1.6.50.10		74,4	52,6	42431	69	410	141	663	6456	1090	720	900	2028	2000	2028	1076	2x2152	22	54	35	25

\* = Sound pressure indication (LpA) at 3 m distance each air cooler (+/- 2 dB(A)), free field conditions, according EN13487

\*\* = Air throw see remark page 5

For moisture carry over see remark pag 5

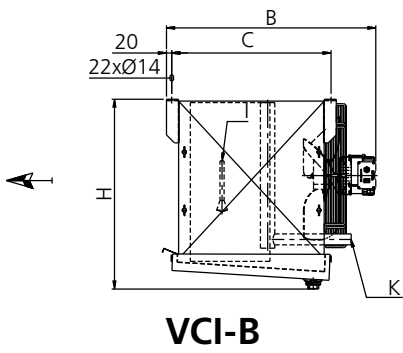

**VCI-B**

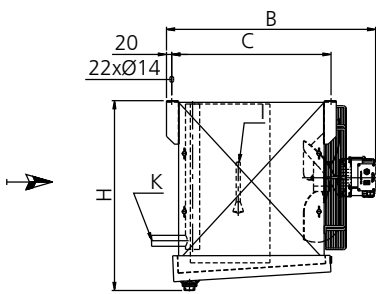

**VCI-Z**

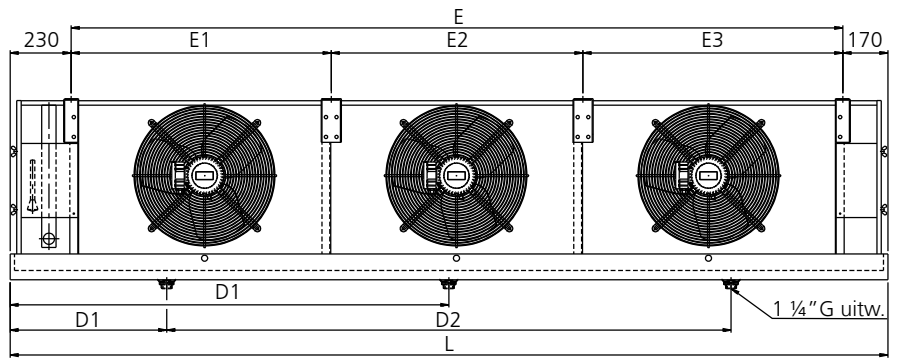



# VCI Electrical defrost

Type VC	Light defrost								Heavy defrost*							
	Coil block			Drip tray				Total each air cooler	Coil block			Drip tray				Total each air cooler
	Number	Type of heating element	Total	Number	Type of heating element	Tension	Total		Number	Type of heating element	Total	Number	Type of heating element	Tension	Total	
	n	mm	kW	aantal	mm	V	kW	kW	n	mm	kW	aantal	mm	V	kW	kW
4.5.45.f	4	4300	7,24	2	4600	200	2,92	10,16	6	4300	10,86	4	4600	200	5,84	16,7
6.5.45.f	6	4300	10,86	2	4600	200	2,92	13,78	8	4300	14,48	4	4600	200	5,84	20,32
8.5.45.f	8	4300	14,48	2	4600	200	2,92	17,4	12	4300	21,72	4	4600	200	5,84	27,56
1.5.45.f	8	4300	14,48	4	4600	200	5,84	20,32	12	4300	21,72	4	4600	200	5,84	27,56
4.5.50.f	4	5200	8,8	2	5500	200	3,52	12,32	6	5200	13,2	4	5500	200	7,04	20,24
6.5.50.f	6	5200	13,2	2	5500	200	3,52	16,72	8	5200	17,6	4	5500	200	7,04	24,64
8.5.50.f	8	5200	17,6	2	5500	200	3,52	21,12	12	5200	26,4	4	5500	200	7,04	33,44
1.5.50.f	8	5200	17,6	4	5500	200	7,04	24,64	12	5200	26,4	4	5500	200	7,04	33,44
4.6.45.f	4	5200	8,8	2	5500	200	3,52	12,32	6	5200	13,2	4	5500	200	7,04	20,24
6.6.45.f	6	5200	13,2	2	5500	200	3,52	16,72	8	5200	17,6	4	5500	200	7,04	24,64
8.6.45.f	8	5200	17,6	2	5500	200	3,52	21,12	12	5200	26,4	4	5500	200	7,04	33,44
1.6.45.f	8	5200	17,6	4	5500	200	7,04	24,64	12	5200	26,4	4	5500	200	7,04	33,44
4.6.50.f	4	6100	10,4	2	6400	200	4,16	14,56	6	6100	15,6	4	6400	200	8,32	23,92
6.6.50.f	6	6100	15,6	2	6400	200	4,16	19,76	8	6100	20,8	4	6400	200	8,32	29,12
8.6.50.f	8	6100	20,8	2	6400	200	4,16	24,96	12	6100	31,2	4	6400	200	8,32	39,52
1.6.50.f	8	6100	20,8	4	6400	200	8,32	29,12	12	6100	31,2	4	6400	200	8,32	39,52
4.7.45.f	4	5800	9,84	2	6400	200	4,16	14	6	5800	14,76	4	6100	200	7,84	22,6
6.7.45.f	6	5800	14,76	2	6400	200	4,16	18,92	8	5800	19,68	4	6100	200	7,84	27,52
8.7.45.f	8	5800	19,68	2	6400	200	4,16	23,84	12	5800	29,52	4	6100	200	7,84	37,36
1.7.45.f	8	5800	19,68	4	6400	200	8,32	28	12	5800	29,52	4	6100	200	7,84	37,36
4.8.45.f	4	6700	11,56	2	7000	200	4,58	16,14	6	6700	17,34	4	7000	200	9,16	26,5
6.8.45.f	6	6700	17,34	2	7000	200	4,58	21,92	8	6700	23,12	4	7000	200	9,16	32,28
8.8.45.f	8	6700	23,12	2	7000	200	4,58	27,7	12	6700	34,68	4	7000	200	9,16	43,84
1.8.45.f	8	6700	23,12	4	7000	200	9,16	32,28	12	6700	34,68	4	7000	200	9,16	43,84

f = Fin spacing

\* = Always heavy electric defrost when using cooling mediums.

# Goedhart standard product information

## Goedhart standard aircooler overview



VCI



DVS/DRS/DZS



ZGB/ZGZ



PAC



FC38



ZFB/ZFZ



# Goedhart air cooler for every application

For Contractors and Original Equipment Manufacturers (OEM) related to the industrial refrigeration industry, GEA Goedhart B.V. offers an unlimited range of air coolers and air cooled condensers in several configurations.

Depending on the application, the optimum configuration will be selected in close cooperation with our customers.

## Configurations

The following material combinations are available in various tube pitches and various fin spacing:

Tube material	Tube configuration	Fin material
Copper (Cu)	38x33, 50x50, 60x60	Aluminium (Al)
Stainless steel (Stst)	38x33, 50x50, 60x60	Aluminium (Al)
Stainless steel (Stst)	50x50	Stainless steel (Stst)
Aluminium (Al)	60x60	Aluminium (Al)
Hot dipped galvanized steel (FeZn)	60x60, 75x75	Hot dipped galvanized steel (FeZn)

## Options on aluminium fins

- Goldlack coated fins
- Seawater resistant aluminium fins (AlMg)

## Applications

Cooling	Freezing
Cold stores / Distribution centres	Cold stores / Distribution centres
Food processing rooms	Tunnel / spiral freezers
Fruit storage	Slaughter houses
Banana ripening storage	Automotive testing rooms
Greenhouse conditioning	Ski domes

## Pressure Equipment Directive (P.E.D.)

All aircoolers produced by Goedhart comply with the Pressure Equipment Directive 97/23/EC. PED certificates can be downloaded from [www.goedhart.nl](http://www.goedhart.nl).





GEA Refrigeration

## GEA Goedhart B.V.

Nijverheidsweg 6, 4695 RC Sint Maartensdijk  
the Netherlands  
Phone +31 (0)166 665 665, Fax+31 (0)166 663 698  
[www.goedhart.nl](http://www.goedhart.nl)  
[info.goedhart.nl@geagroup.com](mailto:info.goedhart.nl@geagroup.com)

GEA Refrigeration

## GEA Goedhart s.r.o.

Kostomlátecká 180, 288 26 Nymburk  
Czech Republic  
Phone +420 (0)325 819 951, Fax+420 (0)325 519 952  
[www.goedhart.cz](http://www.goedhart.cz)  
[goedhart.cz@geagroup.com](mailto:goedhart.cz@geagroup.com)

03.02.2.009.dok - 2009-09 / Subject to modification

All offers, contracts, deliveries and other legal relations from GEA Goedhart B.V. are subject to the latest version of our general sales and delivery conditions as filed at the Chamber of Commerce in Middelburg - The Netherlands

Applicability of the general conditions put forward by any buyer is rejected explicitly by GEA Goedhart B.V.